

# PULSE SYSTEM

## Fiber-Optic Timing Distribution System

Sub-femtosecond optical timing distribution at scale



## DESCRIPTION

PULSE Timing Distribution System delivers optical signals to remote locations with the lowest added timing jitter and drift available on the market. It employs ultralow-noise optical pulse trains from an optical master oscillator (OMO), distributed via stabilized fiber links.

Fiber delay variations are measured with attosecond precision using Cycle's BOC technology and actively compensated, enabling ultra-stable timing transfer over long distances. At fiber link outputs, ultrafast lasers and microwave sources can be synchronized to the OMO with unparalleled performance.

The system is designed for reliable operation in complex environments, featuring automated lock acquisition, comprehensive monitoring of inputs and outputs, and intuitive control via remote or local interfaces with integrated data logging.

## BENEFITS

- State-of-the-art timing jitter and drift across distributed systems
- Modular and scalable system (up to 8 links and 10-km length)
- Remote or local control via EPICS
- Automated search and lock mechanism via GUI
- Advanced monitoring and control features

## APPLICATIONS

- Large-scale facility synchronization (FELs, particle accelerators)
- Distributed laser and RF synchronization networks
- Ultrafast science infrastructures (UED, high-power laser facilities)
- Precision timing distribution networks (e.g. radio telescopes, long-baseline systems)

## SETUP EXAMPLE

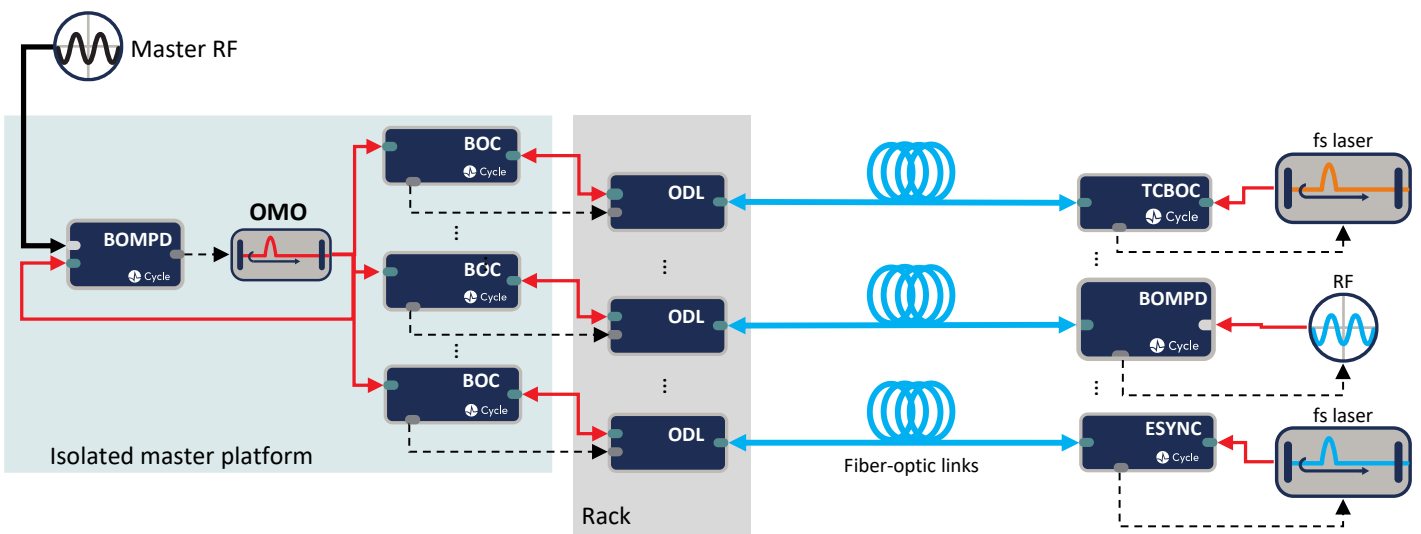



## SPECIFICATIONS

| Parameter                        | Specification  | Comment  |
|----------------------------------|--|--|
| Timing jitter                    | < 5 fs RMS   | integrated residual noise [35 $\mu$ Hz - 1 MHz], i.e., for 8 hours <sup>1</sup>                                      |
| Fiber link type                  | PM or SM fiber   | polarization maintaining or standard single mode fibers  |
| Fiber link length                | < 10 km  | contact Cycle for longer lengths.  |
| Number of fiber links            | Up to 8  | per platform, expendable by combining multiple platforms   |
| Optical wavelength               | 1555 $\pm$ 10 nm   | operating at pulsed mode   |
| Pulse repetition rate            | 100 MHz – 1 GHz  | please consult Cycle GmbH for higher repetition rates.   |
| Control system interface         | EPICS  | via TCP/IP   |
| Integrated feedback              | Included   | applied to OMO, fiber link actuators, etc.   |
| Auto lock                        | Included   | via graphical user interface on a computer   |
| Dimensions                       | 1.6 $\times$ 1.4 $\times$ 0.6 m <sup>3</sup><br>19" rack | isolated & stabilized master platform for optical modules<br>temperature-controlled rack for opto-electronic modules |
| <b>Fiber link output options</b> |  |  |
| Optical PULSE receiver           | PM or SM fiber   | > 10 mW output, stabilized OMO pulse train   |
| RF PULSE receiver                | SMA  | ultra-low noise RF signals at any harmonic of pulse rep. rate  |
| BOC / TCBOC                      | PM fiber   | input to a BOC/TCBOC for remote laser synch.   |
| BOMPD                            | PM fiber   | input to a BOMPD for remote RF synch.  |
| ESYNC                            | PM or SM fiber   | input to a ESYNC for remote laser/RF synch.  |
| EDFA                             | PM fiber   | ultra-low noise in-loop EDFA with > 100 mW total output power to support 8 additional fiber links                    |

<sup>1</sup> system shall be in a thermally controlled environment (temperature +18 to +24°C, with slope < 0.4°C/h and variation < 1°C pk-pk; humidity < 60 %RH with variation < 10 %RH pk-pk).

## MEASUREMENT DATA

Timing distribution performance of a PULSE System with 150-m fiber links:

Out-of-loop timing jitter

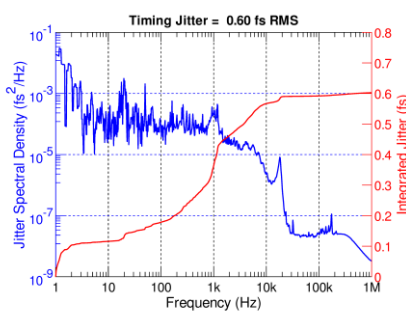

ADEV

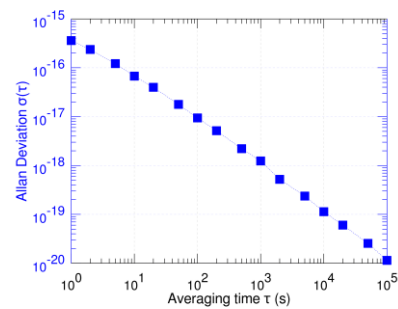

Out-of-loop timing drift

