

## 2051 nm Narrow Linewidth Single-Frequency Fiber Laser AP-SF1

### Applications:

- Quantum Computation
- LIDAR
- Gas sensing

### Features:

- Spectral Linewidth < 10 kHz
- Single Longitudinal Mode
- Low Phase Noise and RIN
- Turn-key System



### Optical Characteristics:

Parameter	Specification
Operation Mode	CW
Operating Wavelength	2051 nm
Output Power	10 W
Power Tuning Range	10-100%
Power Stability (4 hours RMS)	< 1%
Spectral Linewidth	< 10 kHz
Beam Quality, $M^2$	< 1.1
Beam Diameter	1-2 mm
Polarization Extinction Ratio	Linear Polarization, > 20 dB
Fast Tuning Range (option)	>20 MHz/V
Fast Tuning Bandwidth	>1 kHz
Thermal Tuning Range (option)	0.1-0.3 nm
Relative Intensity Noise	
Output Delivery	Single Mode PM Fiber, FC/APC connector, or Free Space Collimated Output

(For special requirement, please contact AdValue Photonics for options.)

*Specifications subject to change without notice*

## General Characteristics:

Parameter	Specification
Operating temperature	20 to +35 °C
Storage temperature	-10 to +70 °C
Cooling	Water
Power requirement	AC 100~240 V (50/60Hz)
Warm-up time	10 minutes
Package dimensions	448.6(W) x 433(D) x 132.5(H) mm

## Mechanical Outline:

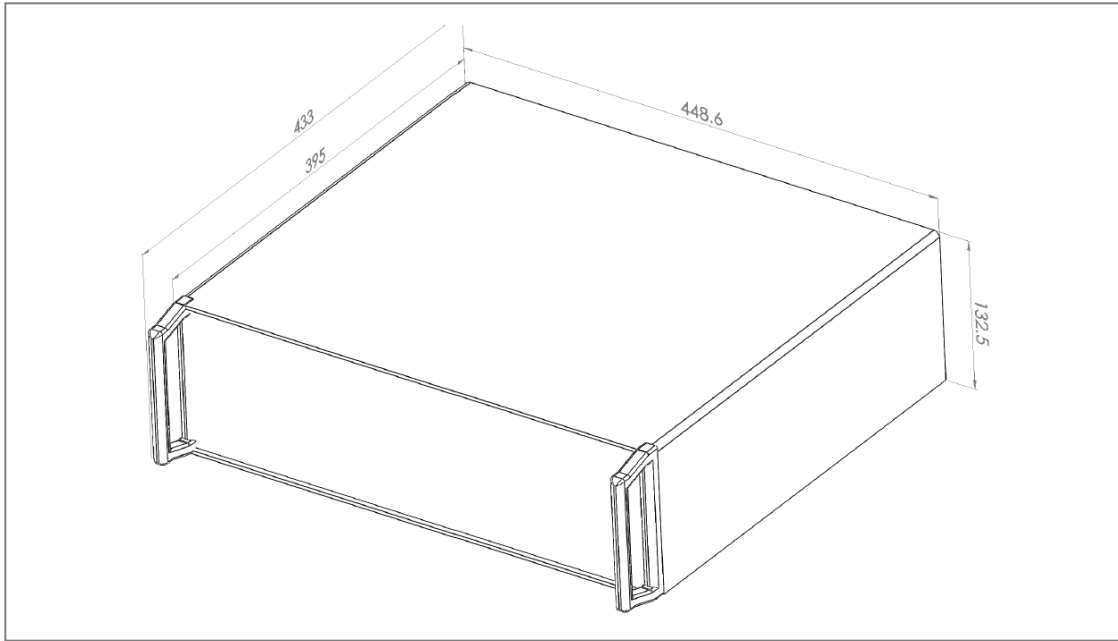

## Ordering Information:

Part Number:	AP-SF1	-	xxxx	-	xx	-	xx
			Standard Wavelength: 1950 = 1950 nm Custom Wavelength: xxxx = xxxx nm		Output Power: 01 = 1 W 05 = 5 W		Polarization: RP = random polarization LP = linear polarization



Specifications subject to change without notice